



IP AUDIO MODULE

300

Development Specification

Advanced multiformat audio decoder module with network, USB and serial interface, adding IP based streaming and controlling capabilities to OEM products

Document version 01.02

Release date 14. Aug. 2009

© 2009 Barix AG, all rights reserved. All information is subject to change without notice. All mentioned trademarks belong to their respective owners and are used for reference only.



Table of Contents

Table of Contents.....iii

Introduction..... I

Hardware features.....	I
Related products.....	I
Applications.....	I
Available Firmware.....	I

Hardware2

Mechanical drawing.....	2
Block diagram.....	3
Network Interface.....	3
Serial Interfaces.....	3
Digital Audio.....	3
Analog Audio.....	3
Peripheral I/O.....	3
Power supply.....	3

Connectors.....4

Connector placement.....	4
Connector Pin out CON1.....	4
Connector Pin out CON2.....	4
Connector Pin out CON3.....	4
Connector Pin out CON4.....	4

Layout guidelines.....5

General rules.....	5
Carrier PCB view.....	5

Technical data.....6

CPU's, speed, memory.....	6
Audio processor.....	6
Non-volatile storage.....	6
Serial Interfaces.....	6
Network Interfaces.....	6
Peripheral I/O.....	6
Required connectors.....	6
Input Power Range.....	6
Power Consumption.....	6
Dimensions.....	6
Weight.....	6
Environmental conditions.....	6

Introduction

The Barix IP AUDIO MODULE 300 allows manufacturers of traditional audio devices to add network capabilities to their products.

Hardware features

The Barix IP AUDIO MODULE 300 features:

- High quality, multi standard audio decoding in formats: G.711, WAV, MP3 Layer 1 and 2, AAC+, Ogg Vorbis, WMA
- Stereo output
- I²S bus (Inter-IC Sound)
- Integrated CPU / MAC / IO controller
- 100Mbit Ethernet port (with PHY)
- 2 KB EEprom for configuration store
- 1 MB Flash memory for application and web server content
- TTL level UART
- USB1.1 interface,
- 4 GPIOs
- Small form factor
- Low Power consumption, runs off a single +3.3Volt (+/-5%) DC power source

Related products

The Barix IP AUDIO MODULE 300 is built into the following Barix products:

- Exstreamer 100
- Exstreamer 110 (integrated LC Display and IR receiver)
- Exstreamer 200 (integrater power amplifier)

Barix recommends the Exstreamer 100 device for evaluation purposes prior to development of an own carrier board. The Exstreamer 100 can be powered by 9 to 30 VDC and features LAN, RS-232 and USB interfaces, headphones and RCA audio outputs, a reset button and two status LEDs.

The Exstreamer 100 and 200 behave the same in regards to hardware interfaces (no external inputs/ outputs besides the standard RS-232 I/Os).

The Exstreamer 110 comes with a built-in relay (connected to PIO#30).

See also Pin #4 in the section "Connector Pin out CON1" in chapter "Connectors".

Applications

The Barix IP AUDIO MODULE 300 is suitable in the following application fields:

- Multiroom or multizone distributed audio systems
- Commercial audio streaming applications (airports, hotels, etc.)
- Realtime audio bridging over IP (when used with the Instreamer)
- Paging and announcement applications (receiver only)
- Instore audio distribution (realtime) for retail, restaurants, franchises

Available Firmware

The Barix IP AUDIO MODULE 300 comes preloaded with a bootloader and can be loaded with different firmware packages featuring:

- Embedded and robust operating system with fully routable IP stack
- IP standard based protocols (TCP/IP, UDP, HTTP, ICMP, SNMP)
- Supports BootP, DHCP and Auto IP
- Integrated web server for configuration, control, update and streaming functions
- Fully documented Application Programming Interface (API)
- Highly customizable User Interface (HTML) with development kit
- Special software features in OEM versions on request

Hardware

Mechanical drawing

The Barix IP AUDIO MODULE 300 provides four, standard 2,54mm spacing, single row pin headers and can be therefore plugged onto the target connector or motherboard.

For mechanical fixation, the board provides two 2.7mm mounting holes for 2.5mm screws. The total size is 56.1mm +/-0.2 by 33.0mm +/-0.2.

Maximum component height is 5.6mm. Using standard distance bolts of 6mm a total height of 9mm above the carrier board can be achieved when mounted on a carrier board by means of soldering the pin headers into holes of the carrier board directly.

Using single row female headers (counterpart to pin headers) the height will increase and must be measured by the integrator (our experience in production shows a minimal height of 11.5mm above the carrier board without using distance bolts and 12mm using 9mm distance bolts). Although the total height is increased, the advantage of being able to replace a module should be considered.

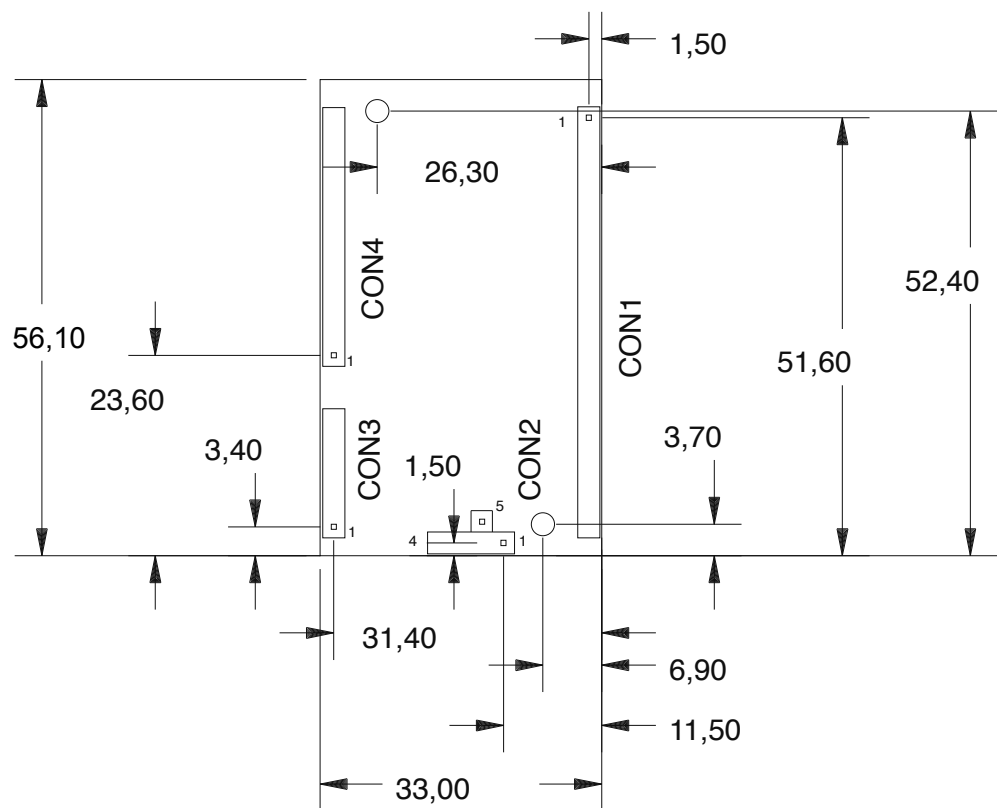

Drawing shows component side.

Dimension is metric (mm)

Drawing is not to scale

Tolerance of PCB dimension is +/-0.2mm, others 0.1mm

Block diagram

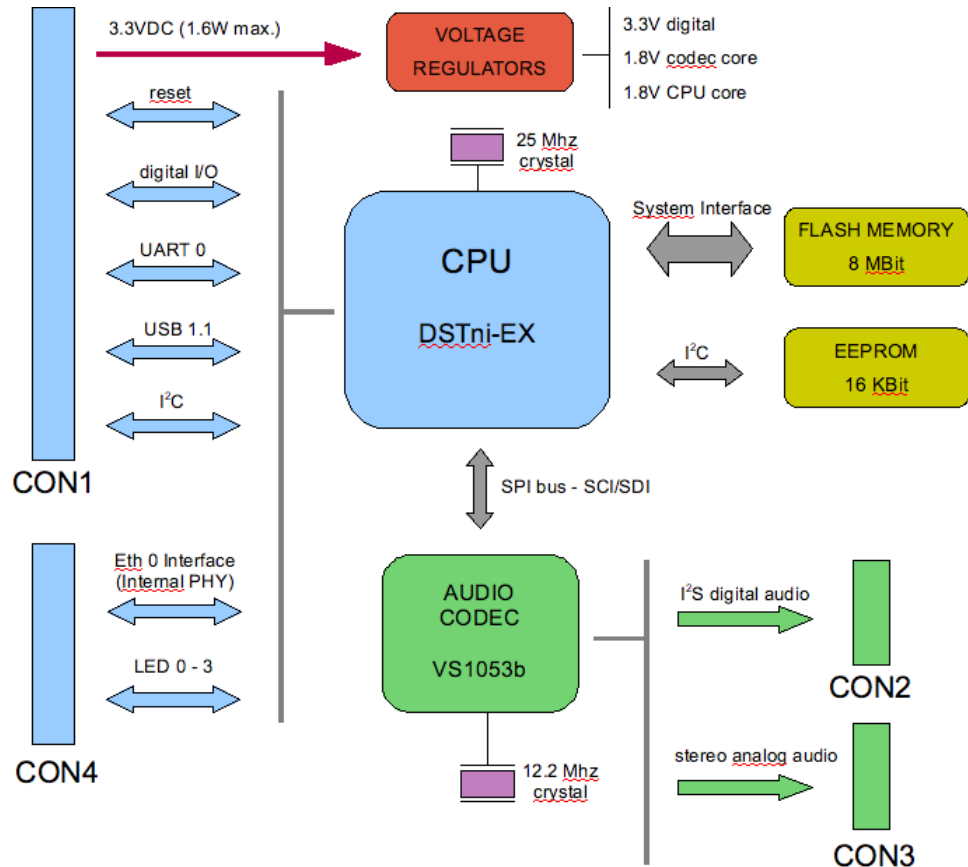

Network Interface

1 x PHY (TP or FO), 2 ETH Status LEDs

The IP AUDIO MODULE 300 is equipped with one on-chip physical layer (PHY) Ethernet interface (10/100MBit, full / half duplex, auto negotiation) which supports either a twisted pair port or a fiber optic link. Four pins (LED.0 to .3) can be used to attach dual color Ethernet status LEDs.

Serial Interfaces

UART (TTL level, TX, RX, RTS, CTS), 1 x USB 1.1

The serial port UART0 can be used to build serial standard interfaces like RS-232 or RS-485 by attaching external driver chips. Special serial framing (9bit protocols, bi-phase encoding etc) or speeds (up to 1MBit) can be implemented for OEM versions.

One USB 1.1 standard interface is provided on connector J1 for memory use (up to 4 GB, FAT 12 or FAT 16 formatted).

Digital Audio

I²S (Inter-IC Sound)

The I²S interface can be used to connect to I²S capable devices.

Analog Audio

1 x Stereo Output (L&R), 1 x Microphone Input (balanced) or 1 x Stereo Input

Three analog audio interfaces are provided on the Barix IP Audio Module.

The stereo output can be used to connect to analog amplifiers or directly to headphones (30Ohm).

The microphone (differential inputs, self-biasing) allows the use of a wide selection of microphones (dynamic, capacitive, FET amplified). The positive microphone input pin is shared with the left line input so either Mic or Line In can be selected at a time.

The stereo line inputs allows the connection of analog audio sources with Line outputs.

Peripheral I/O

7 x PIO

Of the seven 3.3VDC digital I/Os available on the IP AUDIO MODULE 300 four can be used freely by OEM software as either input or output as three are reserved for designated functions (see below). The inputs tolerate 5VDC Logic Level and outputs supply 3.3VDC.

Reservations:

- One I/O pin is used as a hardware input for the Reset button
- Two I/O pins serve as a user interface for driving status LEDs (green and red)
- During initialization PIO#17 is pulled down for 500usec in order to detect 1-wire devices

Power supply

1 x VIN, 5 x DGND, 1 x AGND

One connector pins is provided to power the Barix IP Audio Module from a single +3.3 Volt DC power source. One ground pin for power and 4 ground pins for the digital interfaces are provided. The maximum power consumption is 1.6 Watt.

A separate ground is provided for the audio interfaces.

Connectors

Connector placement

For connector placement (and type) please refer to the mechanical drawing in chapter Hardware.

Connector Pin out CON1

Pin #	Name	Type	Description (usage)
1	-RST	D	Active low Reset I/O (Hardware reset from power surveillance)
2	TMR.0	I/B	Timer 0 external input / PIO #11 (GPIO)
3	DGND	P	Digital Ground
4	PIO30	B	DSTni EX PIO #30 (GPIO / Relay I on Exstreamer I10)
5	PIO29	B	DSTni EX PIO #29 (GPIO)
6	PIO25	B	DSTni EX PIO #25 (Red status LED)
7	PIO24	B	DSTni EX PIO #24 (Green status LED)
8	PIO17	B	DSTni EX PIO #17 (GPIO/I-wire*)
9	PIO8	B	DSTni EX PIO #8 (Button for Reset/Factory defaults/Bootloader)
10	DGND	P	Digital Ground
11	VIN	P	Audio module input Voltage 3.3 VDC
12	CTS.0	I	UART 0 flow control input
13	RTS.0	O	UART 0 flow control output
14	RXD.0	I	UART 0 receive data
15	TXD.0	O	UART 0 transmit data
16	DGND	P	Digital Ground
17	USB-	B	USB 1.1 Host Interface negative
18	USB+	B	USB 1.1 Host Interface positive
19	I2CCLK	B	I ² C Clock (Connected internally / Internal testing only)
20	I2CDAT	B	I ² C Data (Connected internally / Internal testing only)

Type: O=Output, I=Input, P=Power, B=bidirectional, D = Open Drain (pull-up resistor on module)

* During initialization PIO#17 is pulled down (to GND) for 500usec in order to detect attached I-wire devices ! Nevertheless it can be used as a push button input (to GND), as a logic input (needs a current limiting resistor) or as an active high logic output (needs a 2K7 pull down resistor).

Connector Pin out CON2

Pin #	Name	Type	Description
1	SOC	O	I ² S serial clock output
2	SOD	O	I ² S serial data output
3	SOI	O	I ² S frame indication
4	DGND	P	Digital Ground
5	MCLK	O	Digital interface master clock

Type: O=Output, P=Power

Connector Pin out CON3

Pin #	Name	Type	Description (usage)
1	MIC1-	AI	Not supported (Internal testing only)
2	MIC1+	AI	Not supported (Internal testing only)
3	AGND	P	Audio Ground
4	INM	AI	Not supported (Internal testing only)
5	OUTL	AO	Left channel audio output
6	OUTR	AO	Right channel audio output

Type: AO=Audio Output, AI=Audio Input, P=Power

Connector Pin out CON4

Pin #	Name	Type	Description
1	TX+	O	PHY level positive Transmit
2	TXCT	R	Transmit Transformer center Tap
3	TX-	O	PHY level negative Transmit
4	DGND	P	Digital Ground
5	RX-	I	PHY level negative Receive
6	RXCT	R	Receive Transformer center Tap
7	RX+	I	PHY level positive Receive
8	DGND	P	Digital Ground
9	LED.3	O	see DSTni EX manual
10	LED.2	O	see DSTni EX manual
11	LED.1	O	see DSTni EX manual
12	LED.0	O	see DSTni EX manual

Type: O=Output, I=Input, P=Power, R = Reference level

Layout guidelines

General rules

- A low ESR Capacitor of 10uF to 47uF in parallel to a low loss ceramic 100nF capacitor is recommended as power supply bypass close to the Barix Audio Module's power supply pins.
- All available ground pins of the Barix Audio Module should be attached to their respective ground domain.
- Avoid any connection of ground domains on the Carrier PCB as the ground interconnection is made on the Barix Audio Module already.
- Avoid signal trace routing crossing domain borders.
- Restricted Area A must not contain any high current switching circuitry nor any components creating magnetic flux.
- Flood unused PCB areas with copper and connect those planes to it's respective ground.
- The corresponding counterparts (for connectors CON1 to 4) to be placed on motherboard are standard 2,54mm spacing, single row female headers.
- Designers should use good PCB layout techniques suited for high speed bidirectional data bus design when the USB signal run is more than a few cm in length
- The USB signal lines should be of equal electrical length and track width for their entire length
- The USB signal lines include provision for termination resistors. The exact value of the terminations may need to be checked or confirmed by a designer, but in the range of about 30 to 100 ohms is most likely. These terminations should be close to either the USB socket or the IPAM unit
- A more complex (capacitive) termination may be needed under some circumstances.

Carrier PCB view

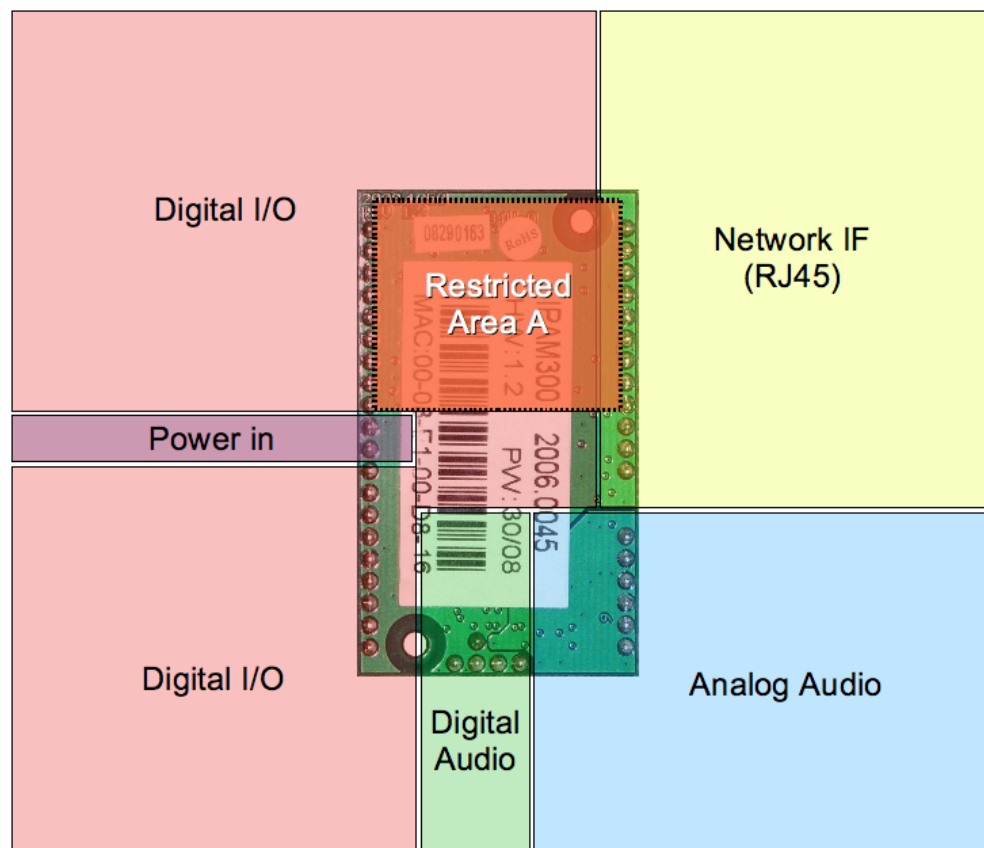

Technical data

CPU's, speed, memory	Lantronix DSTni-EX, 12-125MHz clock software selectable, 256 KB zero wait state static RAM																					
Audio processor	<p>VLSI VSI053b - AUDIO CODEC</p> <ul style="list-style-type: none"> • G.711 (μLaw / aLaw 8 to 48 kHz sampling rate) • WAV (IMA ADPCM + 16bit PCM uncompressed : 8 to 48 kHz) • MP3 Layer 1 (32, 44.1 and 48 kHz , CBR +VBR +ABR) • MP3 Layer 2 (16, 22.05 and 24 kHz, CBR +VBR +ABR) • AAC+ (HE-AAC v2 Level 3, incl. SBR and PS) needs licensing by OEM • Ogg Vorbis (floor 1) • WMA 4.0/4.1/7/8/9 all profiles (5-384 kbps) 																					
	<table border="1"> <thead> <tr> <th>Parameter</th> <th>Value</th> <th>Unit</th> </tr> </thead> <tbody> <tr> <td>Full Scale Output Voltage (Peak-to-peak)</td> <td>1.5</td> <td>V_{pp}</td> </tr> <tr> <td>Output Total Harmonic Distortion</td> <td>0.07</td> <td>%</td> </tr> <tr> <td>Output S/N Ratio (full scale signal)</td> <td>94</td> <td>dB</td> </tr> <tr> <td>Interchannel Isolation (Cross Talk)</td> <td>53</td> <td>dB</td> </tr> <tr> <td>Analog Output Load Resistance</td> <td>16</td> <td>Ω</td> </tr> <tr> <td>Analog Output Load Capacitance</td> <td>100</td> <td>PF</td> </tr> </tbody> </table>	Parameter	Value	Unit	Full Scale Output Voltage (Peak-to-peak)	1.5	V _{pp}	Output Total Harmonic Distortion	0.07	%	Output S/N Ratio (full scale signal)	94	dB	Interchannel Isolation (Cross Talk)	53	dB	Analog Output Load Resistance	16	Ω	Analog Output Load Capacitance	100	PF
Parameter	Value	Unit																				
Full Scale Output Voltage (Peak-to-peak)	1.5	V _{pp}																				
Output Total Harmonic Distortion	0.07	%																				
Output S/N Ratio (full scale signal)	94	dB																				
Interchannel Isolation (Cross Talk)	53	dB																				
Analog Output Load Resistance	16	Ω																				
Analog Output Load Capacitance	100	PF																				
Non-volatile storage	1MB Flash ROM (approximately 700KB available for user data) 2KB EEPROM for configuration																					
Serial Interfaces	UART (TTL level, TX, RX, RTS, CTS) 300 Baud to 230 kBaud, 1 x I ² S-Bus, 1 x USB 1.1																					
Network Interfaces	1 x 10/100 Base (integrated PHY for twisted pair or fiber optic link)																					
Peripheral I/O	7 x inputs/outputs (inputs 5VDC tolerant, outputs 3.3VDC), 4 GPIOs for OEM use (1 GPIO selectable as hardware timer input, 1 GPIO shared with I-wire bus), 1 GPIO reserved for reset button, 2 GPIOs pins serve as a user interface driving green and red status LEDs																					
Required connectors	The corresponding counterparts (for connectors CON1 to 4) to be placed on motherboard are standard 2,54mm spacing, single row female headers. The module can be alternatively soldered instead of plugged.																					
Input Power Range	3.3VDC nominal (min. 3.135 VDC / max. 3.465VDC)																					
Power Consumption	max. 1.6 Watt																					
Dimensions	56.1mm +/-0.2 by 33.0mm +/-0.2 2 mounting holes for 2.5mm screws (drill size 2.7mm). Maximum component height 5.6mm. (total 9mm when soldered on carrier board, 12 when plugged)																					
Weight	approx. 14g																					
Environmental conditions	32 ~ 131° F / 0 ~ 55° C, < 85% relative humidity (non-condensing)																					

© 2009 Barix AG, Zürich, Switzerland.

All rights reserved.

All trademarks belong to their respective owners and are used for reference only.

Barix and Barix IP Audio Module are trademarks of Barix AG, Switzerland and are registered in certain countries.

Newest information about our devices is available via download from our website, www.barix.com.

We explicitly reserve the right to change and improve the product without notice.

Barix AG
Seefeldstrasse 303
8008 Zürich
SWITZERLAND

T +41 43 433 22 11
F +41 44 274 28 49

www.barix.com
sales@barix.com
support@barix.com

