



BARIX IO12

BARIX IO12

I/O to RS-485 Modbus converter
for commercial interfacing,
control and home automation
applications

Barix AG
Seefeldstrasse 303
CH-8008 Zürich
Switzerland
T +41 43 433 22 11
F +41 44 274 28 49

Barix Technology Inc.
2182 Helena Road
St. Paul, MN 55128
USA
T (866) 815-0866
F (209) 755-8435



PRODUCT MANUAL

Version: 01.06

Date: 11/02/2005

For Firmware Version 4

www.barix.com
info@barix.com

Table of Contents

Introduction.....	1
--------------------------	----------

Hardware.....	2
Case.....	2
Connectors.....	2
Power supply requirements.....	2
Inputs.....	2
Outputs.....	2
RS-485.....	2
LED Indicators.....	3
Configuration Memory.....	3

Connectors.....	4
Connector Pin out overview.....	4
J5 Pin out VIN.....	4
J7 Pin out OUT 1..6.....	5
J8 Pin out OUT 7..12.....	5
J9, J10 Pin out Extension Connectors.....	6
J9, J10 Extension Cable.....	6
J11 Pin out RS-485.....	6
J2 Pin out IN 1..4.....	7
J4 Pin out IN 5..8.....	7
J6 Pin out IN 9..12.....	8

Protocol support.....	9
General.....	9
Supported Standard Commands.....	9
Special Commands.....	9
Exceptions.....	10
Command 69.....	10

Command 70.....	11
Command 71.....	11

Configuration.....	12
Default Parameters.....	12

Connecting I/O.....	13
Connecting inputs.....	13
Connecting outputs.....	14

Connecting a Barix Barionet controller.....	15
Power wiring.....	15
RS-485 wiring.....	15
Reference wire.....	16
RS-485 termination.....	16

Modbus Register Map.....	17
Live I/O.....	17
Configuration Data.....	18
Complete Register Map.....	20
Complete Coils Map.....	20

Technical specifications.....	21
CPU.....	21
Inputs.....	21
Outputs.....	21
I/O, RS-485, Power Connectors.....	21
Host Interface.....	21
Power Supply Requirements.....	21
LED Indicators.....	21
Case.....	21
Misc.....	21
Conformity.....	21

Introduction

The BARIX IO12 are I/O to RS-485 Modbus converters for commercial interfacing, control and home automation applications.

Using the industry standard Modbus/RTU protocol over 2-wire RS-485 the device can be controlled from any Modbus capable master.

Twelve independent inputs and twelve independent outputs allow the use of the BARIX IO12 in a wide range of I/O applications:

- Digital input to RS-485 converter (12 optical isolated inputs)
- RS-485 to digital output converter (12 sourcing outputs)

The device is configured via the serial interface using standard Modbus read/writes. If the device ID is unknown, a special command is available, which can be sent via broadcast and uses the serial number of the device to send it new configuration info.

The protocol supported is Modbus/RTU at 19200 (default) and 9600 Baud, with even (default) or no parity.

Hardware

Case	The BARIX IO12 I/O to RS-485 Modbus converter is in a plastic DIN-rail mounting case.
Connectors	Power, RS-485, I/Os are available on detachable screw connector blocks for wires AWG28 - AWG16 / 0.08 - 1.3 mm ²
Power supply requirements	The BARIX IO12 is equipped with a universal power input and accepts both AC and DC voltage. The AC supply range is 12 to 24 Volts and 9 to 30 Volts when powered by a DC power supply. A voltage regulator controls the internally needed operating voltage of 5VDC and consumes with all outputs activated 1 Watt max. The BARIX IO12 power supply input is reverse polarity protected.
Inputs	All input pins are optically isolated in groups of four inputs and incorporate ESD protection ($\pm 6\text{kV}$), transient burst protection ($\pm 4\text{kV}$) and input current limitation ($R_I=1.2\text{k}\Omega$) and allow input signals up to 32VDC. This allows interfacing of up to three devices with different ground levels, supplying up to 4 digital signals each. Two additional wires, carrying power supply (up to 32VDC) and ground, are needed for the input circuitry on each input connector block.
Outputs	Two output connector blocks with six outputs each allow the use of two different output power supplies (up to 32VDC) for the sourcing outputs. Each output can source up to 700 mA while the output voltage is only 0.3V max below the applied output supply voltage.
RS-485	The BARIX IO12 has an RS-485 host interface, available on a three pin screw contact connector block as well as on two expansion connectors (4 pins). Besides "A" and "B" signals for the differential, bidirectional bus signal, a third connection is available, commonly referred to as "reference ground". This signal is internally tied to signal ground via a 100 Ohm series resistor.

Termination resistors are NOT provided on-board. A termination resistor may be added at each end of the RS-485 bus if required.

The BARIX IO12, as well as other Barix I/O extension units, feature soft pull-up (B) and pull down (A) 10kOhm resistors, which force the inactive bus to a relatively high impedance, idle condition.

Both A and B line signals are protected against ESD (Electrostatic Discharge).

Supported interface configurations are

19200 baud, 8bit, even parity, 1 stop bit (**default**)
19200 baud, 8bit, no parity, 1 stop bit
9600 baud, 8bit, even parity, 1 stop bit
9600 baud, 8bit, no parity, 1 stop bit

LED Indicators

Two LED indicators on the unit show the power status as well as RS-485 transmit activity.

Configuration Memory

The BARIX IO12 contains 256 bytes of non volatile configuration memory (EEPROM) which can be read and (most of it) written via standard Modbus commands.

Connectors

Connector Pin out overview

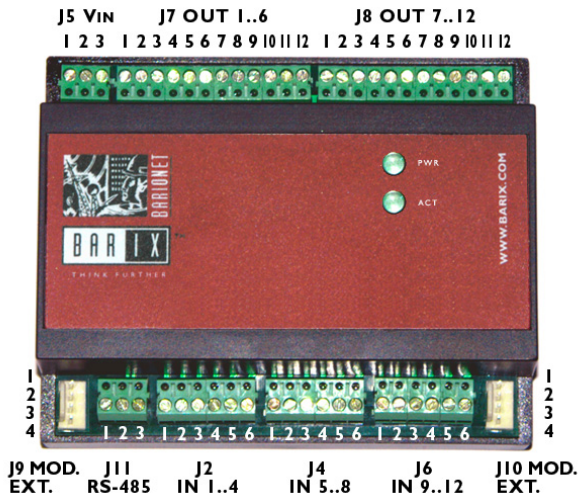

J5 Pin out V_{IN}

Power supply input of the BARIX IO12.



Pin	Function	Pin	Function
1	+ V_{IN} or AC-1 in	3	GND or AC-2 in
2	Not connected		

Externally powered outputs 1 to 6 of the BARIX IO12.

**J7 Pin out
OUT 1..6**

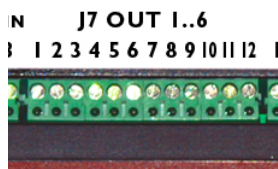

Pin	Function	Pin	Function
1	+VOUTSUPPLY(1..6)	7	Output 4
2	+VOUTSUPPLY(1..6)	8	Output 5
3	+VOUTSUPPLY(1..6)	9	Output 6
4	Output 1	10	GNDOUTSUPPLY(1..6)
5	Output 2	11	GNDOUTSUPPLY(1..6)
6	Output 3	12	GNDOUTSUPPLY(1..6)

**J8 Pin out
OUT 7..12**

Externally powered outputs 7 to 12 of the BARIX IO12.

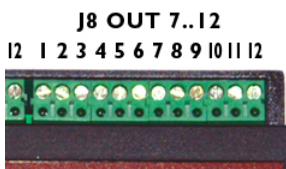

Pin	Function	Pin	Function
1	+VOUTSUPPLY(7..12)	7	Output 4
2	+VOUTSUPPLY(7..12)	8	Output 5
3	+VOUTSUPPLY(7..12)	9	Output 6
4	Output 1	10	GNDOUTSUPPLY(7..12)
5	Output 2	11	GNDOUTSUPPLY(7..12)
6	Output 3	12	GNDOUTSUPPLY(7..12)

J9, J10 Pin out Extension Connectors

J9 and J10 (Molex, p/n 22-27-2041, 4A max) are provided for easy connection of multiple devices, and are located at the left and right sides. They carry the unregulated supply voltage and RS-485 bus signals.

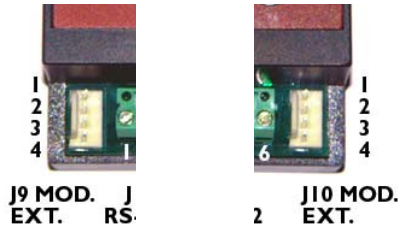

Pin	Function	Pin	Function
1	+VIN	3	RS-485 A
2	GND	4	RS-485 B

J9, J10 Extension Cable

Use the supplied 3"/75mm extension cable to connect another Barix device (eg. Barix IO12, Barix R6 etc.). The cable consists of 2 Crimp Terminal Housings Molex 22-01-3047 and 8 female Crimp Terminals Molex 08-52-0123 of Molex 2695 series.

J11 Pin out RS-485

J11 can be used to connect the RS-485 bus to the unit. These screw terminals are electrically identical to the expansion connectors J2 and J4. In addition, a "reference ground" is provided and connected to the ground of the BARIX IO12 via a 100 Ohm resistor and can be used for grounding applications.

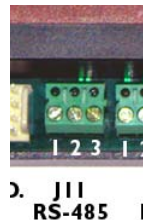

Pin	Function	Pin	Function
1	Reference GND	3	RS-485 B
2	RS-485 A		

**J2 Pin out IN
1..4**

Externally powered optical isolated inputs 1 to 4.

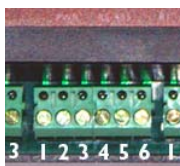

**J2
85 IN 1..4**

Pin	Function	Pin	Function
1	+VINSUPPLY(1..4)	4	Input 3
2	Input 1	5	Input 4
3	Input 2	6	GNDINSUPPLY(1..4)

**J4 Pin out IN
5..8**

Externally powered optical isolated inputs 5 to 8.

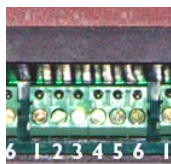

**J4
IN 5..8**

Pin	Function	Pin	Function
1	+VINSUPPLY(5..8)	4	Input 7
2	Input 5	5	Input 8
3	Input 6	6	GNDINSUPPLY(5..8)

**J6 Pin out IN
9..12**

Externally powered optical isolated inputs 9 to 12.

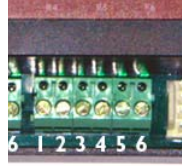

**J6 J
IN 9..12 E**

Pin	Function	Pin	Function
1	+VINSUPPLY(9..12)	4	Input 11
2	Input 9	5	Input 12
3	Input 10	6	GNDINSUPPLY(9..12)

Protocol support

General

The BARIX IO12 communicates via the Modbus/RTU protocol over its RS-485 interface. The unit is also configured via writes to Modbus registers. In addition to the actual I/O registers, a 256 byte information area is accessible which contains device type, software version, serial number, the configuration as well as user changeable storage.

Attention:

Writing to information area registers (setup flash memory) can take up to 10 milliseconds per address before being confirmed (Modbus acknowledge).

Supported Standard Commands

The following standard Modbus commands are supported by the BARIX IO12. All other commands will be answered with an exception code. Due to the limited memory resources of the BARIX IO12, the unit cannot receive messages larger than 95bytes and will ignore these (e.g. write multiple register commands).

CMD (hex)	Function
03 (0x03)	read (holding) register
04 (0x04)	read input register
05 (0x05)	write single coil
06 (0x06)	write single register
16 (0x10)	write multiple registers

Special Commands

The BARIX IO12 supports some special, Barix proprietary, commands which have been implemented to ease configuration and facilitate the use of the BARIX IO12 in conjunction with non-Modbus systems. These commands are:

CMD (hex)	Function
68 (0x44)	set all outputs on multiple units
69 (0x45)	set configuration using serial number
70 (0x46)	set coil without acknowledge
71 (0x47)	erase firmware, enter download mode with setting 9200,n,8,l

Exceptions

The BARIX IO12 responds to malformed commands or access violations with the defined Modbus exceptions.

Command 69

The command code 69 (hex 45) is used to set a BARIX IO12 device which is connected to the bus and whose address is unknown (but serial parameters are correct).

The command can also be sent multiple times with different serial parameters to find the device. The serial number of the device, which can be found on a label on the unit (format xxx-yyy), needs to be inserted into this block to address a specific unit. The block is sent out as a Modbus "broadcast".

Bytes 272, 273, 274, 275 of the Modbus register map (configuration memory positions 16..19) will be written with the provided information if the serial number matches.

Command format:

Byte 1	- 0xff	(broadcast address)
Byte 2	- 0x45	(command code)
Byte 3	- s1	(serial number, first part)
Byte 4	- s2	(serial number, second part)
Byte 5	- s1	(serial number, first part, repeated)
Byte 6	- s2	(serial number, second part, repeated)
Byte 7	- c1	(configuration data for register 272)
Byte 8	- c2	(configuration data for register 273)
Byte 9	- c3	(configuration data for register 274)
Byte 10	- c4	(configuration data for register 275)
Byte 11	- crc1	(crc1 according to Modbus spec)
Byte 12	- crc2	(crc2 according to Modbus spec)

Despite the broadcast addressing, the unit will respond with an acknowledge (containing bytes 1..6 plus crc) !

Command 70

The command code 70 (hex 46) is used to set an BARIX IO12 output without a return acknowledgment. The command uses the exact syntax of the 05 (set coil) command, but the BARIX IO12 does not send an answer and is immediately ready to receive the next message. The command should be sent addressed to the device address and NOT as a broadcast, otherwise all BARIX IO12 units on the bus will react to it.

This command has been added to the BARIX IO12 to allow slow systems, which are not Modbus native and cannot react fast to serial input (like common home automation systems) to set a series of outputs of one or multiple BARIX IO12 units without the need to observe Modbus message timeouts, answers etc.

Command 71

The command code 71 (hex 47) is used to erase the firmware of a BARIX IO12 device which is connected to the bus and whose address is unknown (but serial parameters are correct). The serial number of the device, which can be found on a label on the unit (format xxx-yyy), needs to be inserted into this block to address a specific unit. The block is sent out as a Modbus "broadcast".

After erasing the firmware the device will go into a simple bootloader with serial settings 19200,n,8,1.

Command format:

Byte 1	- 0xff	(broadcast address)
Byte 2	- 0x45	(command code)
Byte 3	- s1	(serial number, first part)
Byte 4	- s2	(serial number, second part)
Byte 5	- s1	(serial number, first part, repeated)
Byte 6	- s2	(serial number, second part, repeated)
Byte 7	- crc1	(crc1 according to Modbus spec)
Byte 8	- crc2	(crc2 according to Modbus spec)

Configuration

Default Parameters

The BARIX IO12 is configured via the RS-485 interface using standard Modbus commands.

If the address of the device is not known, it can be temporarily set to default parameters by setting a jumper in the device. No reset is necessary. Within 5 seconds after applying the jumper, the default parameters are assumed. It is NOT necessary to reset or to power cycle the device after removing the jumper ! If no valid Modbus blocks are received by the relay unit for a 5 second time interval, the serial interface is reset and reconfigured with stored parameters.

Use a screw driver to remove the snap-on case top. On one side of the case lift one latch first and gently pull the top then lift the second latch and remove the top completely.

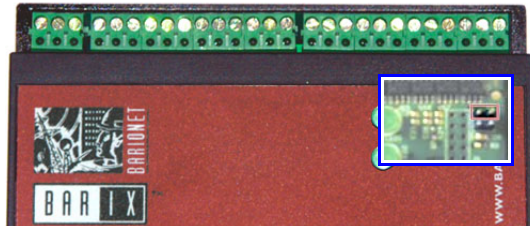

J3 is a 4 pin connector and is located next to LED1 and LED2. To set default parameters connect the upper two pins using a standard jumper (not included).

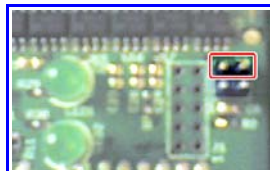

When the jumper is set, the default parameters are:

Serial interface 19200 Baud, even parity, 1 stop bit
 Modbus Address 255

Connecting I/O

Connecting inputs

The BARIX IO12 features 12 optical isolated inputs in groups of 4 inputs per connector block. Each block must be powered from the same power supply as the connected device.

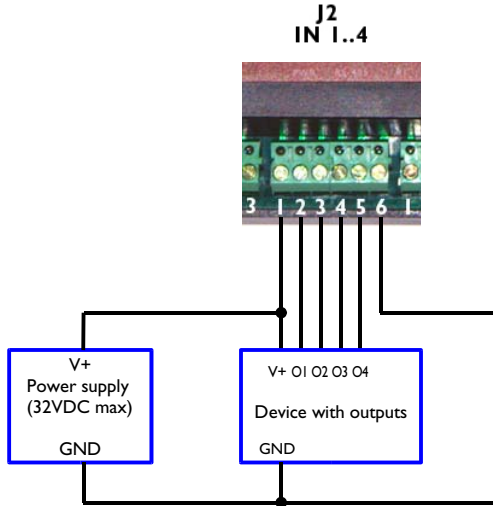

Each used connector block (J2,J4,J6) must be powered on Pin 1 and grounded on Pin 6 (as shown in picture above) in order to function correctly.

This can be done by up to three independently powered devices connecting them on the three connector blocks separately (multiply the above schematic for J4 and/or J6).

When only one device (with up to 12 outputs) is connected to the BARIX IO12 the single power supply must be wired to Pin 1 and Pin 6 on all used connector blocks (J2,J4,J6).

Connecting outputs

The BARIX IO12 features 12 sourcing outputs in groups of 6 outputs per connector block. Each block must be powered from the same power supply as the connected device.

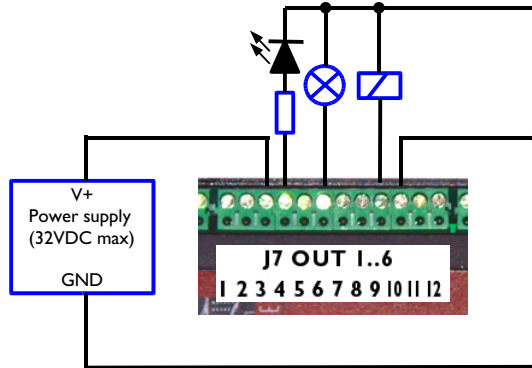

Both connector blocks (J7 and J8) must be powered either on Pin 1,2 or 3 and grounded either on Pin 10,11 or 12 in order to function correctly.

Pins 1 to 3 as well as Pins 10 to 12 are connected internally to ease wiring.

This can also be done using two separate power supplies as long as the connected loads are correctly wired to the respective power supply ground (multiply the above schematic for J8).

Connecting a Barix Barionet controller

Power wiring

The Barix Barionet provides a detachable screw block for I/Os and power. The Barix Barionet is powered using pin 15 (Vcc) and pin 16 (Vss). In order to power the BARIX IO12 connect two wires to the Barix Barionet:

- connect Pin 16 (J6) to Pin 3 (J5) of the BARIX IO12 (GND)
- connect Pin 15 (J6) to Pin 1 (J5) of the BARIX IO12 (+V_{IN})

Attention: When using an AC power supply make sure to attach the same polarity (AC-1) to the Vcc/Vin input on all Barix devices and the other phase (AC-2) to the Vss/GND inputs.

Wiring the polarity incorrectly can destroy the attached devices !

Therefore we suggest to use wires with different colors (i.e. White for Vcc, Black for GND).

RS-485 wiring

Connecting the RS-485 bus is simple as the RS-485 signals are available on J7 which is also a detachable screw terminal block:

RS 422/485

6 5 4 3 2 1



Pin	485
1	Reference GND
2	Not used
3	Not used
4	RS-485 A
5	RS-485 B
6	Reference GND

- connect Pin 4 to Pin 2 (J11) of the BARIX IO12 (RS-485 A)
- connect Pin 5 to Pin 3 (J11) of the BARIX IO12 (RS-485 B)

When communication problems occur the following two measures can be taken to improve the RS-485 signal quality.

Reference wire

When using two separate power supplies a third wire should be used to ensure a common voltage level :

- Connect Pin 1 or Pin 6 (J7) to Pin 1 (J11) of the BARIX IO12

RS-485 termination

When the two devices need to be connected over a long distance both sides of the cable should be terminated using selected resistors to suppress signal reflections (a good starting point is a value of 600 Ohms but has to be adjusted to the actual cable length and impedance, the resistance used should not be smaller than 470 Ohms):

- Connect the resistor between Pin 4 and Pin 5 (J7) directly at the terminals of the Barionet controller
- Connect the resistor between Pin 2 and Pin 3 (J11) directly at the terminals of the BARIX IO12

Modbus Register Map

The BARIX IO12 supports all 64k address locations in the Modbus address maps, however, unimplemented locations either read as “0” or generate an exception when read or written.

The Modbus address range is divided into multiple address maps, all 65535 registers in size. The BARIX IO12 implements the “coils” (64k, 1bit) and the “registers” (64k, 16 bit). Reading back discrete (1bit) values is not supported in the current firmware.

Attention: all Modbus addresses count from 1, while the protocol addresses start at 0. Example: Modbus register 1 is addressed in Modbus/RTU as “0”. This documentation uses the Modbus register number – in the protocol the address must be one less !!

Live I/O

The state of the outputs can be set/reset using “set coil” and “write register” commands. In addition, the state of the outputs can be read back using the “read holding register” command.

In the “coil” address map, only positions 1..12 (Modbus/RTU addresses 0..11) are populated in the BARIX IO12, which are mapped to outputs 1..12. Write access to any other address is prohibited and will generate an exception.

In the “register” address map, the outputs can be written simultaneously by accessing register 1. Bit 0 is output 1, bit 1 is output 2, ... bit 11 is output 12.

The state of the inputs can be read using the “read input register” command or the “read holding register” on register 2.

Configuration Data

All configurable parameters are accessible using standard Modbus read/write commands to registers.

The configuration information area is 256 bytes, which is accessible as 256 byte register (lower 8 bits only), register 257..512 in the Modbus memory map.

The first 16 bytes of the configuration registers are “one-time” writable only – after setting these registers to a value not equal to 255 (hex 0xFF) they can not longer be changed. All other registers can be read and written. Within these first 16 bytes, Device type, software version, and serial number are stored.

In addition, the installer of the unit can use 8 bytes to write permanent information (like shipping date, system ID where the unit is installed etc).

Attention: This 8 bytes are “one-time” writable only – after setting these registers to a value not equal to 255 (hex 0xFF) they can not longer be changed.

Of the remaining 240 bytes, the first 16 bytes have a special meaning (configuration registers) – all other registers (290..512) can be used by the installer/customer to store an to retrieve custom information.

ID registers

Device information such as device ID, software version etc can be accessed using standard register read commands.

This information is read-only and cannot be overwritten.

The information is accessible using standard reads from addresses 257..264.

Register 257: device type, “0xB3” (stands for BARIX IO12)

Register 258: software version, 4 at the time of printing.

Register 259: first part of the serial number (byte)

Register 260: second part of the serial number (byte)

Register 261..264 are reserved for future use by Barix

Register 265..272 are usable as one-time writable storage by the installer or controlling software.

Configuration registers

Device configuration can be set and read using standard Modbus commands. The BARIX IO12 will reset its actual communications parameters to these values anytime it does not receive valid host communication for more than 5 seconds.

Register 273: Reserved

Register 274: Serial interface mode:

Bit 0: 9600 (set) or 19200 (reset) baud

Bit 1: reserved

Bit 2: reserved

Bit 3: direct I/O (set) or debounced (reset)

Bit 4: "sticky IO" (set) or standard (reset)

Bit 5: IO/Change indication (set) or standard Modbus

Bit 6: Reserved

Bit 7: No (set) or even (reset) parity.

Register 275: This register holds the Modbus address of the unit.

Register 276..289: Reserved for future enhancements.

Complete Register Map

Detailed “register” map – again – please note that the protocol address in Modbus/RTU is the register number less one !!

Register	Function
1	Live I/O (Byte, output state bit 0..11)
2	Live I/O (Byte, input state bit 0..11)
3..256	Reserved, reads as “0”
257	Device type (hex B3 for IO12)
258	Firmware version (4 for at time of printing)
259	Serial number 1 st part
260	Serial number 2 nd part
261..264	Reserved, reads as “0xFF”
265..272	One-time writable for installer
273	Reserved, reads as “0xFF”
274	Serial interface mode
275	Modbus address
276..289	Reserved, reads as “0xFF”
290..512	Memory for installer/software use
513....	not accessible
65536	

Complete Coils Map

Detailed “coils” map – please note that in the protocol, address in Modbus/RTU is the coil number less one !!

Coil	Function
1..12	Output 1..12
7..65536	Reserved, do not access

Technical specifications

CPU	PIC 16F877A, 20MHz clock frequency
Inputs	12 optically isolated inputs (0 to 32VDC), grouped to four inputs per connector. External power supply (up to 32VDC) for the protection circuit (ESD $\pm 6\text{kV}$, transient burst $\pm 4\text{kV}$, current limited: $R_I=1.2\text{k}\Omega$) on each connector block needed
Outputs	12 sourcing outputs grouped to six outputs per connector, up to 0.7 A per output, output voltage drop max. 0.3V @ 0.7 A. Separate power supply pins (up to 32VDC) on each connector block.
I/O, RS-485, Power Connectors	Detachable screw contact connector blocks for wires AWG28 - AWG16 / 0.08 - 1.3 mm ²
Host Interface	RS-485: 9600 and 19200 Baud, 8 bit, even or no parity.
Extension Connectors	2 extension connectors (4 pin Molex 22-27-2041, 4A max.) with RS-485 and power terminals, extension cable (3"/75mm) included (2 Crimp Terminal Housings Molex 22-01-3047 and 8 female Crimp Terminals Molex 08-52-0123 of Molex 2695 series)
Power Supply Requirements	12 to 24 VAC / 9 to 30 VDC 1 Watt max.
LED Indicators	1 LED for power status 1 LED for active traffic indication
Case	High quality plastic, 90 grams, DIN-rail mountable 4.13" x 3.34" x 2.83"/105mm x 85mm x 32mm
Misc.	Internal connector for default settings jumper
Environmental conditions	Temperature: 32 to 104° F / 0 to 40° C Humidity: < 70% relative humidity non-condensing
Conformity	FCC A and B, CE A and B Emission EN60730-1:2000 (Class B) Immunity EN60730-1:2000

© 2005 Barix AG, Zürich, Switzerland.

All rights reserved.

The newest information about our devices and the latest version of this manual is available via download from our website, www.barix.com.

We explicitly reserve the right to change and improve the product without notice.

All trademarks mentioned belong to their respective owners.

Barix, BARIX IO12 and Barionet are trademarks of Barix AG, Switzerland and are registered in certain countries.

Barix AG

Seefeldstrasse 303
8008 Zürich
SWITZERLAND

Phone: +41 43 433 2211
Fax: +41 44 274 2849

Internet

web: www.barix.com

email: sales@barix.com

Barix Technology Inc.

2182 Helena Rd.
St. Paul, MN 55128
USA

Phone: (866) 815-0866
Fax: (209) 755-8435

